

# BENCH OWNER'S MANUAL



## IMPORTANT PRECAUTIONS

### FOR HOUSEHOLD USE ONLY

Read all instructions and follow it carefully before using your machine. This machine is intended for household use only. It is not designed for commercial use. Inspect your exercise machine prior to exercising to ensure that all nuts and bolts are fully tightened before each use.

### WARNING

Before commencing with any exercise program, please consult your family physician. If at any time during exercise you feel faint, dizzy or experience pain, stop and consult your family physician. In the event any of the above mentioned warnings are breached by the consumer, the manufacturer may use same as a defense to any claim for injuries, damage or loss. The above warnings are in no way intended to limit or modify the consumer's remedies for breach of warranties pursuant to applicable federal and state laws of regulations. They are being supplied strictly to ensure the safety of the individuals using this product.

- Make sure machine is stabilized on the floor and uneven surfaces are leveled before use.
- Exercise equipment has moving parts. In the interest of safety, keep others, especially children age under 12, at a safe distance while exercising.
- Make sure all adjustment devices are fully inserted and properly adjusted before use to avoid injury.
- Remove all jewellery, including rings, chains and pins before commencing exercise.
- It is essential that your weight bench is used only indoors, in a climate controlled room.
- Always wear suitable clothing and footwear during exercise. Do not wear loose fitting clothing that could become entangled with the moving parts of your exercise machine.
- Warm up 5 to 10 minutes before each workout and cool down 5 to 10 minutes afterward. This allows your heart rate to gradually increase and decrease and will help you prevent straining your muscles.
- Never hold your breath while exercising. Breathing should remain at a normal rate in conjunction with the level of exercise being performed.
- Rest adequately between workouts. Muscles tone and develop during these rest periods. Beginners should work out twice a week and increase gradually to 4 or 5 times per week.
- Do not "over train". Incorrect or excessive training may result in injury.



At NO time should pets or children under the age of 12 be closer to the weight bench than 10 feet.  
At NO time should children under the age of 12 use the weight bench.  
Children over the age of 12 should not use the weight bench without adult supervision.

# ASSEMBLY

## ⚠ WARNING

During the assembly process there are several areas that special attention must be paid. It is very important to follow the assembly instructions correctly and to make sure all parts are firmly tightened. If the assembly instructions are not followed correctly, the weight bench could have frame parts that are not tightened and will seem loose and may cause irritating noises. There should be no side-to-side play in the frame uprights. If there is any play in these areas, the weight bench has not been properly assembled. To prevent damage to the weight bench, the assembly instructions must be reviewed and corrective actions should be taken.

Before proceeding, find your weight bench's serial number located on the rear stabilizer tube and enter it in the space provided below. Also locate the model name which is next to the serial number.

ENTER YOUR SERIAL NUMBER AND MODEL NAME IN THE BOXES BELOW:

SERIAL NUMBER:

--	--	--	--	--	--	--	--	--	--	--	--	--	--	--	--	--	--	--	--

MODEL NAME: **HORIZON**

--	--	--	--	--	--	--	--	--	--	--	--	--	--	--	--	--	--	--	--

### SERIAL NUMBER LOCATION

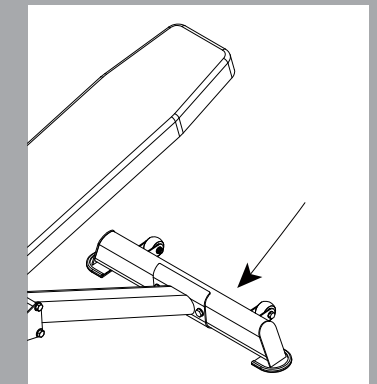

\* Refer to the SERIAL NUMBER and MODEL NAME when calling for service.



ALL MODELS

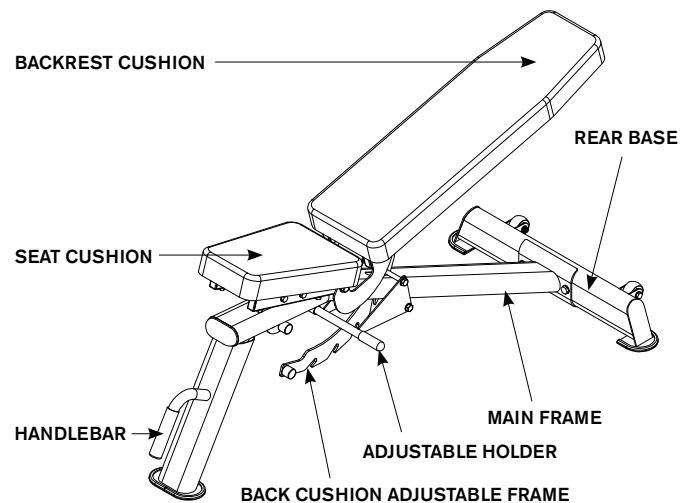

(ADONIS)

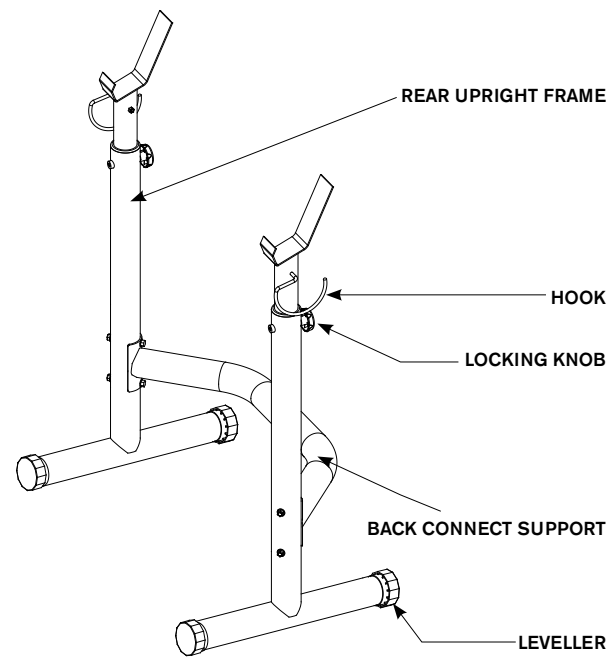

(ADONIS RACK)

### TOOLS INCLUDED:

#### Adonis:

- 2 13/14mm Flat Wrench
- 2 17/19mm Flat Wrench

#### Adonis Rack:

- 1 13/14mm Flat Wrench
- 2 17/19mm Flat Wrench

### PARTS INCLUDED:

#### Adonis:

- 1 Main Frame
- 1 Rear Base
- 1 Seat Cushion Adjustable Frame
- 1 Seat Cushion Tube
- 1 Back Cushion Adjustable Frame
- 2 Back Cushion Tubes
- 1 Adjustable Holder
- 1 Backrest Cushion
- 1 Seat Cushion

#### Adonis Rack:

- 2 Rear Upright Frames
- 1 Back Connect Supports
- 2 Barbell Support

## PRE ASSEMBLY

### UNPACKING

Unpack the product where you will be using it. Place the bench on a level flat surface. It is recommended that you place a protective covering on your floor. Never open box when it is on its side.

NOTE: During each assembly step, ensure that ALL nuts and bolts are in place and partially threaded in before completely tightening any ONE bolt.

NOTE: A light application of grease may aid in the installation of hardware. Any grease, such as lithium bike grease is recommended.

### NEED HELP?

If you have questions or if there are any missing parts, contact Customer Tech Support.



ALL MODELS

## ASSEMBLY STEP 1

### HARDWARE PARTS:

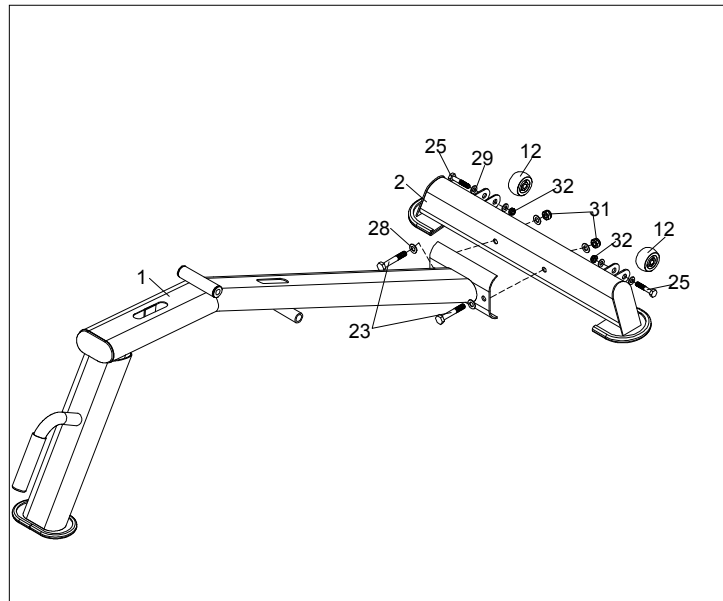
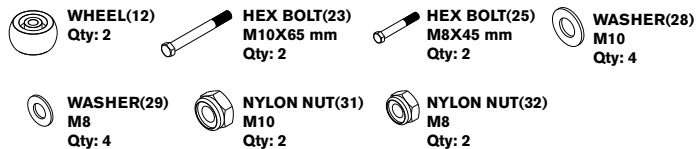

- A Attach the two **WHEELS (12)** to the **REAR BASE (2)**, using two **HEX BOLTS (25)**, four **WASHERS (29)** and two **NYLON NUTS (32)**.
- B Attach the **MAIN FRAME (1)** to the **REAR BASE (2)**, using two **HEX BOLTS (23)**, four **WASHERS (28)** and two **NYLON NUTS (31)**.

## ASSEMBLY STEP 2

### HARDWARE PARTS:

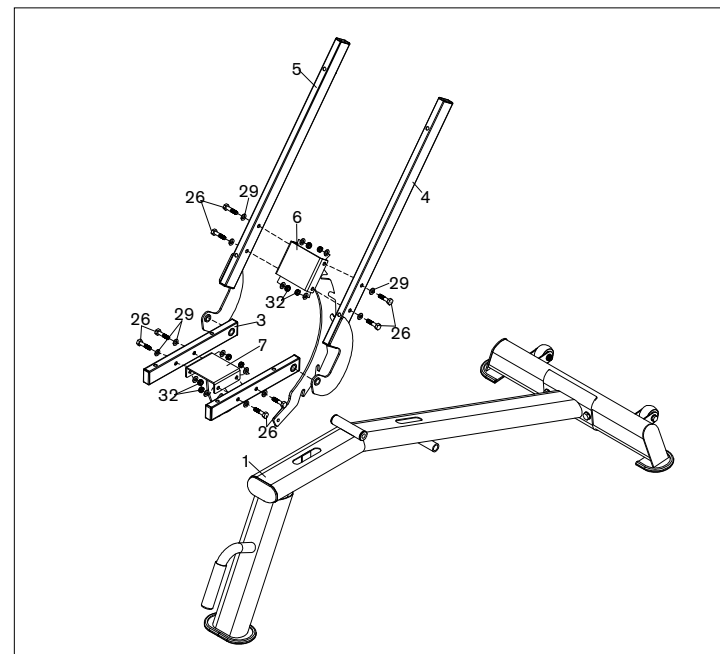
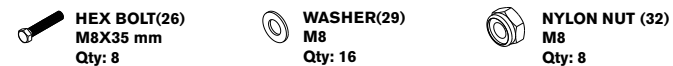

- A Attach the **SEAT CUSHION TUBES (3)** to **SEAT CUSHION ADJUSTABLE FRAME (7)**, using four **HEX BOLTS (26)**, eight **WASHERS (29)** and four **NYLON NUTS (32)**.
- B Attach the **RIGHT and LEFT BACK CUSHION TUBES (5&4)** to **BACK CUSHION ADJUSTABLE FRAME (6)**, using four **HEX BOLTS (26)**, eight **WASHERS (29)** and four **NYLON NUTS (32)**.

## ASSEMBLY STEP 3

### HARDWARE PARTS:

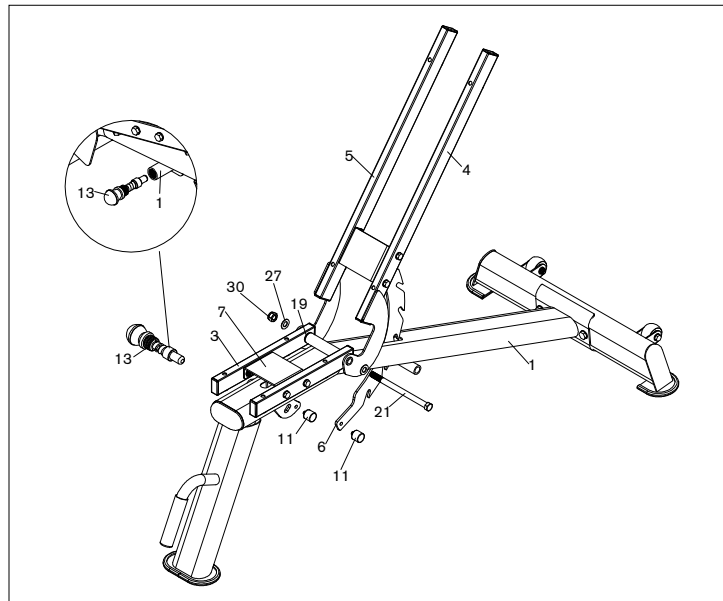
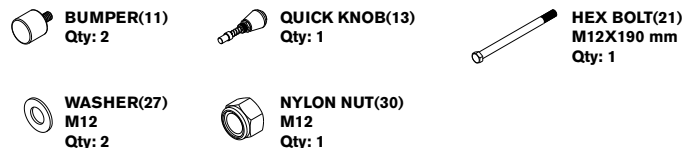

- Attach the **RIGHT** and **LEFT BACK CUSHION TUBE (5&4)** and the **SEAT CUSHION TUBE (3)** to the **MAIN FRAME (1)**, using one **HEX BOLT (21)**, two **WASHERS (27)** and one **NYLON NUT (30)**.
- Insert the **QUICK KNOB (13)** to any one of the holes on the **CURVED PLATE**.
- Attach two **BUMPERS (11)** to the **BACK CUSHION ADJUSTABLE FRAME (6)** and the **SEAT CUSHION ADJUSTABLE FRAME (7)**.

## ASSEMBLY STEP 4

### HARDWARE PARTS:

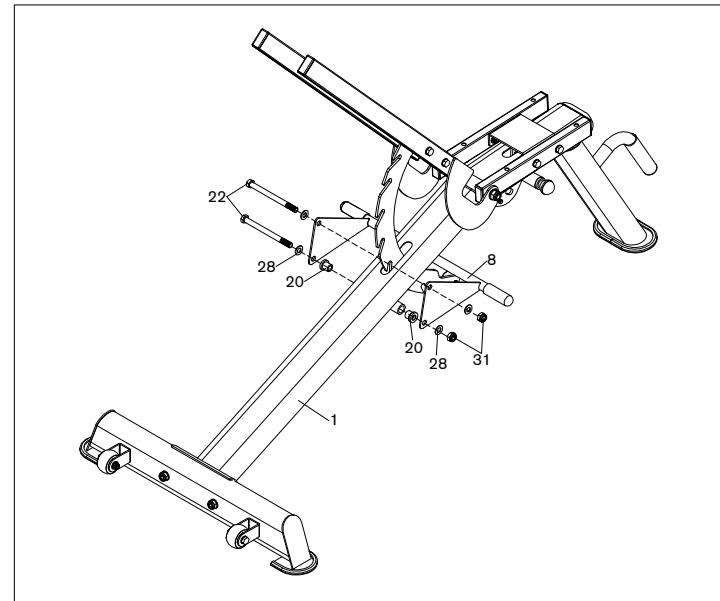

- Attach 2 **PLASTIC BUSHINGS (20)** into both sides of the tube under the **MAIN FRAME (1)**.
- Cross the **ADJUSTABLE HOLDER (8)** to **MAIN FRAME** from bottom side
- Slide 1 **BOLT (22)** through 1 **WASHER (28)**, the left side of **ADJUSTABLE HOLDER (8)**, the tube under the **MAIN FRAME**, the right side of **ADJUSTABLE HOLDER**, 1 **WASHER (28)** and 1 **NUT(31)**.
- Slide 1 **BOLT (22)** through 1 **WASHER (28)**, the left side of **ADJUSTABLE HOLDER (8)**, the left side of **ADJUSTABLE HOLDER**, 1 **WASHER (28)** and 1 **NUT(31)** above the **MAIN FRAME (1)**.



## ASSEMBLY STEP 5

### HARDWARE PARTS:



**HEX BOLT(24)**  
M8X55 mm  
Qty: 8

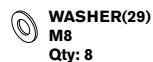

**WASHER(29)**  
M8  
Qty: 8

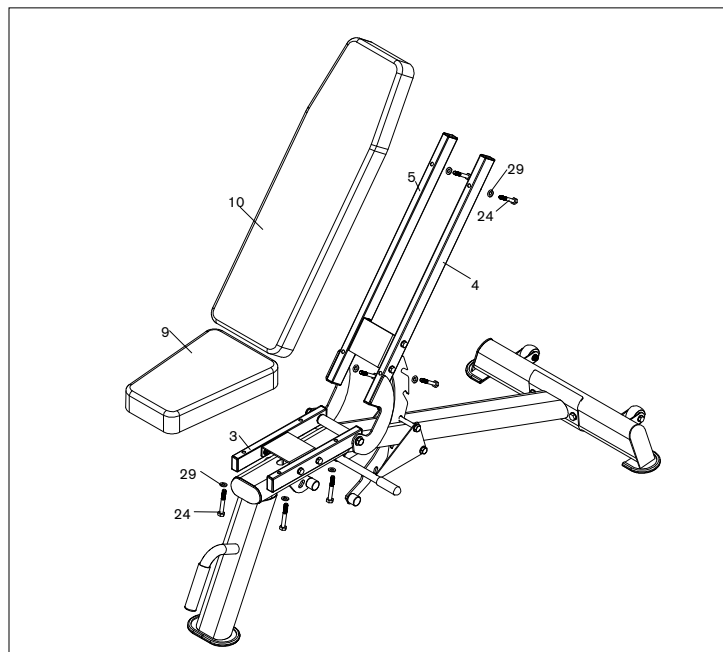

- A Attach the **BACKREST CUSHION (10)** to the **BACK CUSHION TUBES (5&4)**, using four **HEX BOLTS (24)** and four **WASHERS (29)**.
- B Attach the **SEAT CUSHION (9)** to the **SEAT CUSHION TUBES (3)**, using four **HEX BOLTS (24)** and four **WASHERS (29)**.

## ASSEMBLY STEP 6

### ASSEMBLY COMPLETE!

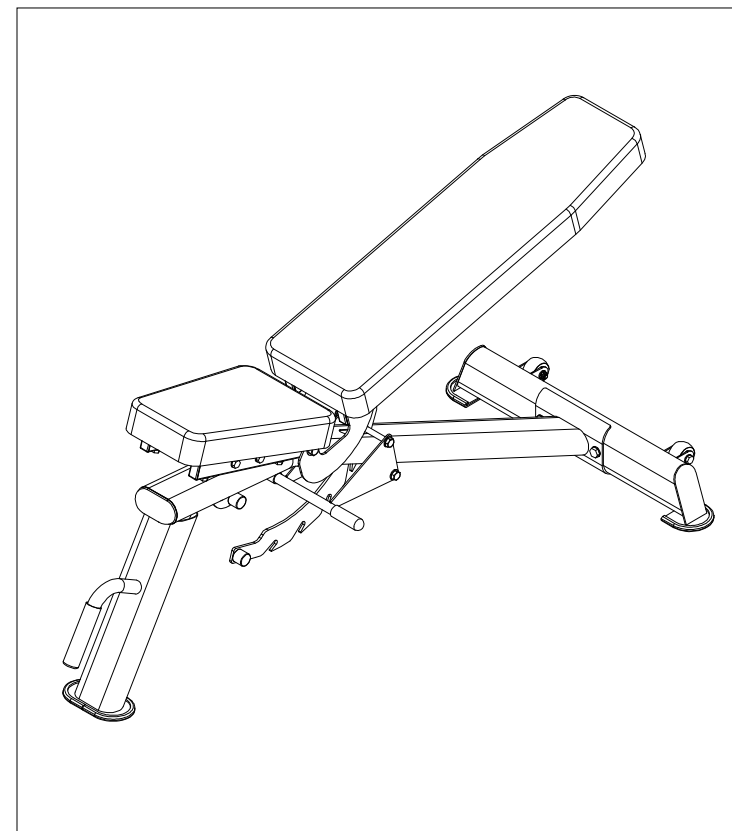

#### Adonis

Max. User Weight: 120 kg / 264 lbs

Max. Training Load: 160 kg / 352 lbs

Product Weight: 19.5 kg / 43 lbs

Overall Dimensions: 141 x 64.5 x 129 cm / 55.5" x 25" x 51"

## ASSEMBLY STEP 1

### HARDWARE PARTS:

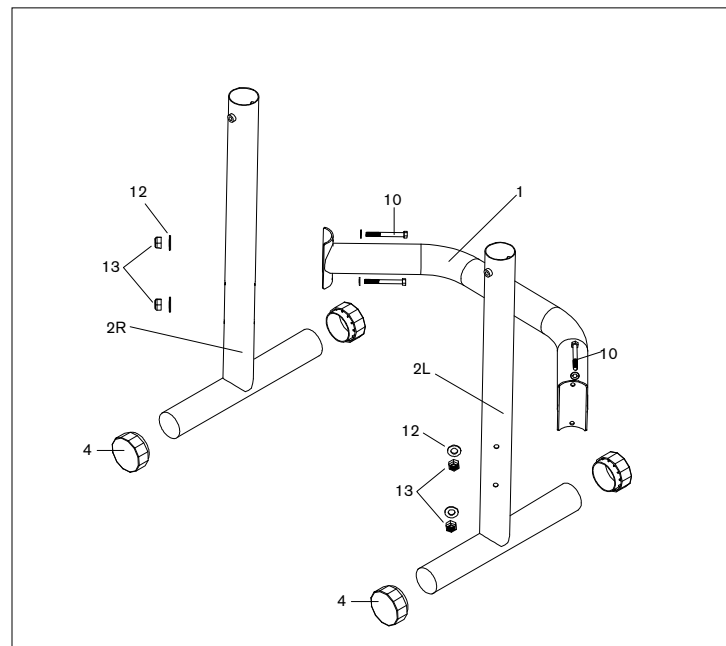
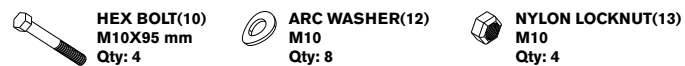

- Attach four **END CAPS (4)** to both of **FRAMES (2L&2R)**.
- Attach **FRAMES (2L&2R)** to **BACK CONNECT SUPPORT (1)** using four **HEX BOLTS (10)**, eight **ARC WASHERS (12)** and four **NYLON LOCKNUTS (13)**.

## ASSEMBLY STEP 2

### HARDWARE PARTS:

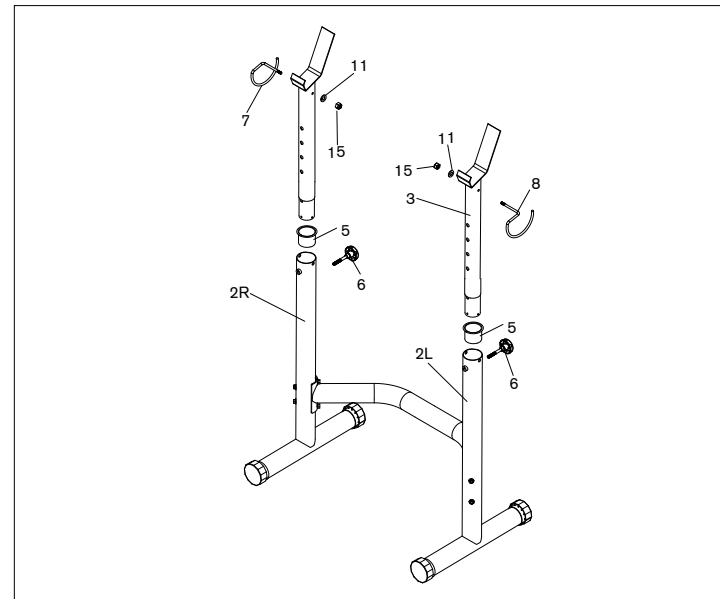
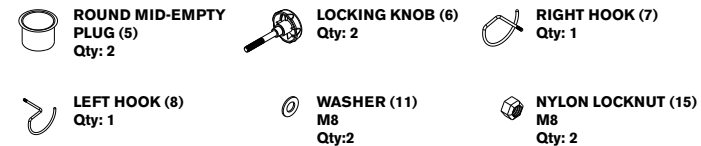

- Fix two **ROUND MID-EMPTY PLUGS (5)** into **REAR UPRIGHT FRAMES (2L&2R)**.
- Slide the two **BARBELL SUPPORTS (3)** to **REAR UPRIGHT FRAMES ( 2L&2R)** and lock with two **LOCKING KNOBS (6)**.
- Attach **RIGHT HOOK (7)** and **LEFT HOOK (8)** to **BARBELL SUPPORTS (3)** using two **NYLON LOCKNUTS (15)** and two **WASHERS (11)**.





## ASSEMBLY STEP 3



ADONIS  
RACK

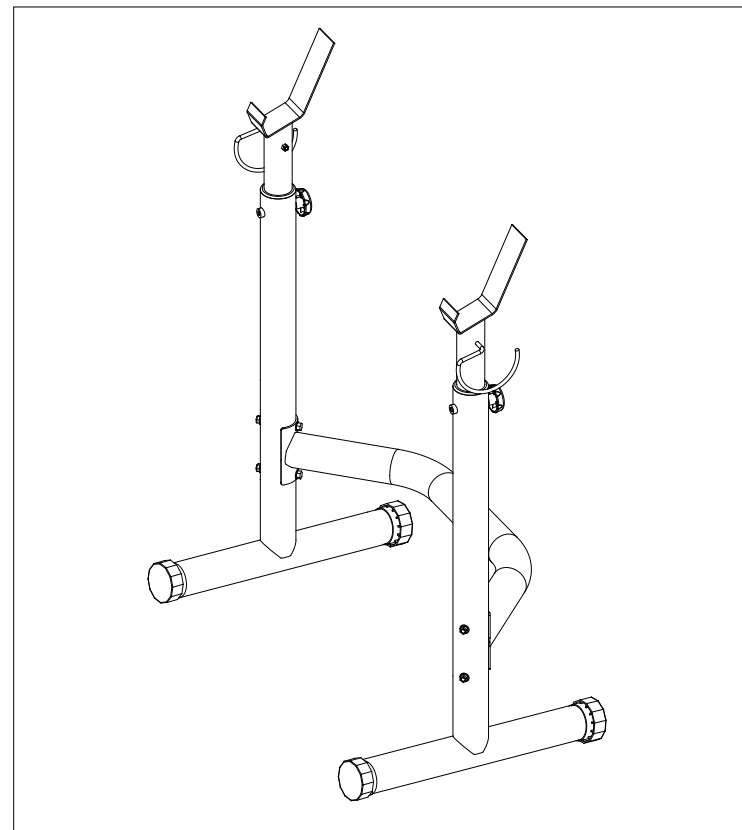

### ASSEMBLY COMPLETE!

#### Adonis Rack

Max. Training Load: 160 kg / 352 lbs

Product Weight: 16 kg / 35 lbs

Overall Dimensions: 62 x 107 x 150 cm / 23.8" x 42" x 59"

Inner Rack Dimensions: 91 cm / 38.5"

Overall Dimensions: 105 cm / 41.3"

## CONDITIONING GUIDELINES

### STRETCH FIRST

Before using your product, it is best to take a few minutes to do a few gentle stretching exercises. Stretching prior to exercise will improve flexibility and reduce chances of exercise related injury. Ease into each of these stretches with a slow gentle motion. Do not stretch to the point of pain. Make sure not to bounce while doing these stretches.

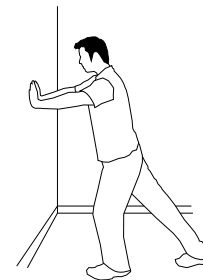

#### 1. STANDING CALF MUSCLE STRETCH

Stand near a wall with the toes of your left foot about 18" from the wall, and the right foot about 12" behind the other foot. Lean forward, pushing against the wall with your palms. Keep your heels flat and hold this position for a count of 15 seconds. Make sure that you do not bounce while stretching. Repeat on the other side.

#### 2. STANDING QUADRICEP STRETCH

Using a wall to provide balance, grasp your left ankle with your left hand and hold your foot against the back of your thigh for 15 seconds. Repeat with your right ankle and hand.

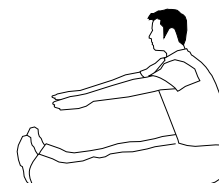
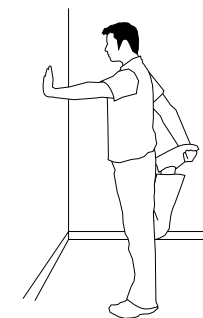

#### 3. SITTING HAMSTRING & LOWER BACK MUSCLE STRETCH

Sit on the floor with your legs together and straight out in front of you. Do not lock your knees. Extend your fingers towards your toes and hold for a count of 15 seconds. Make sure that you do not bounce while stretching. Sit upright again. Repeat one time.



ALL  
MODELS

## ADONIS EXPLODED VIEW

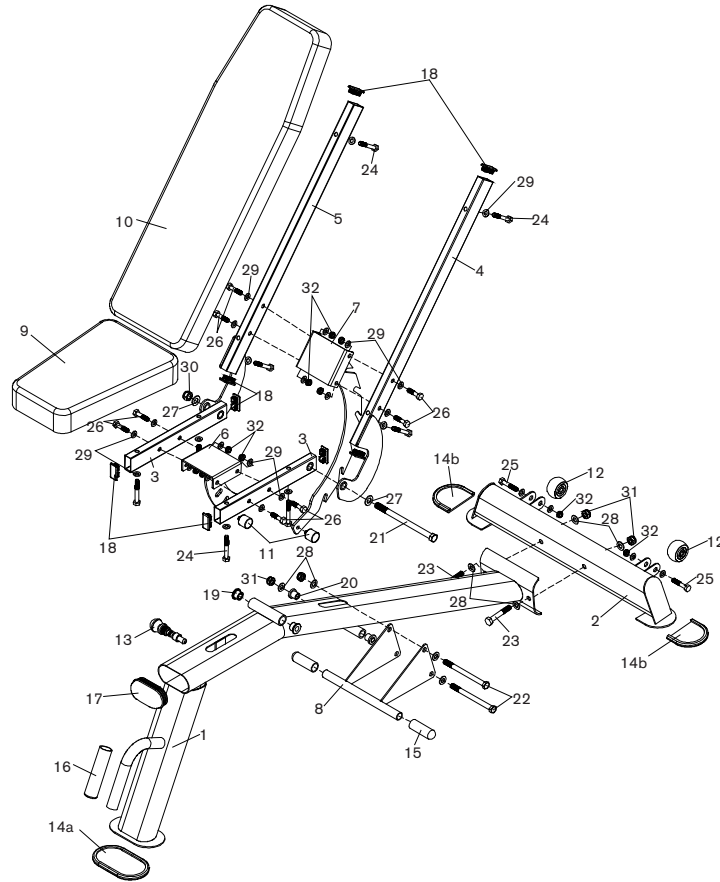

## ADONIS PARTS LIST

NO.	DESCRIPTION	QTY
1	Main Frame	1
2	Rear Base	1
3	Seat Cushion Tube	2
4	Left Back Cushion Tube	1
5	Right Back Cushion Tube	1
6	Back Cushion Adjustable Frame	1
7	Seat Cushion Adjustable Frame	1
8	Adjustable Holder	1
9	Seat Cushion	1
10	Back Cushion	1
11	Bumper	2
12	Wheel	2
13	Quick Knob	1
14a	Rubber Foot Pad (big)	1
14b	Rubber Foot Pad (small)	2
15	Handle Grip(19mm)	2
16	Handle Grip(25mm)	1
17	50 x 100mm Ellipse End Plug	1
18	20 X 40 Square End Plug	8
19	Oil Bushing	2
20	Plastic Bushing	2

NO.	DESCRIPTION	QTY
21	Hex Bolt M12 X 190mm	1
22	Hex Bolt M10 x 130mm	2
23	Hex Bolt M10 x 65mm	2
24	Hex Bolt M8 x 55mm	8
25	Hex Bolt M8 x 45mm	2
26	Hex Bolt M8 x 35mm	8
27	M12 Washer	2
28	M10 Washer	8
29	M8 Washer	28
30	M12 Nylon Nut	1
31	M10 Nylon Nut	4
32	M8 Nylon Nut	10

## ADONIS RACK EXPLODED VIEW

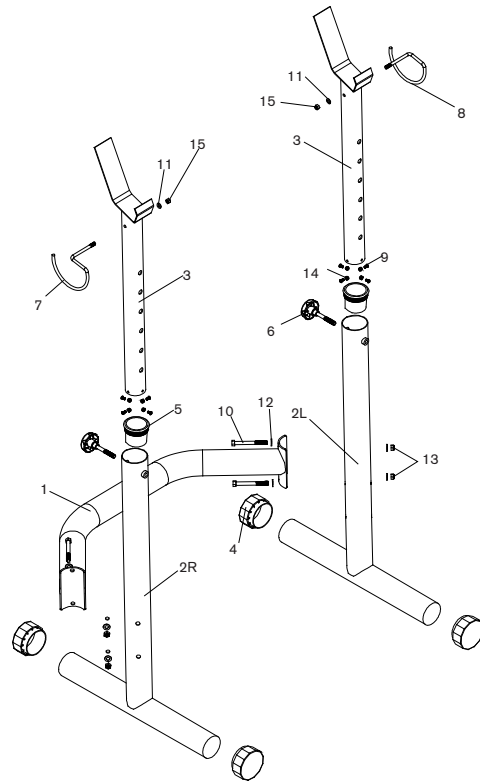

## ADONIS RACK PARTS LIST

NO.	DESCRIPTION	QTY
1	Back Connect Suppor	1
2L	Left Rear Upright Frame	1
2R	Right Rear Upright Frame	1
3	Barbell Support	2
4	Round End Cap (76mm)	4
5	Round Mid-empty Plug	2
6	Locking Knob	2
7	Right Hook	1
8	Left Hook	1
9	Hex Bolt (M6x110mm)	8
10	Hex Bolt (M10x95mm)	4
11	Washer (M8)	2
12	Arc Washer (M10)	8
13	Nylon Locknut (M10)	4
14	Nylon Locknut (M6)	8
15	Nylon Locknut (M8)	2





# BENCH OWNER'S MANUAL

Adonis & Adonis Rack Owner's Manual 0612'12 Rev. 1.6 © 2012 Horizon Fitness